

LONKING 龙工

CDM6035 HYDRAULIC EXCAVATOR

Efficiency Rules the Future

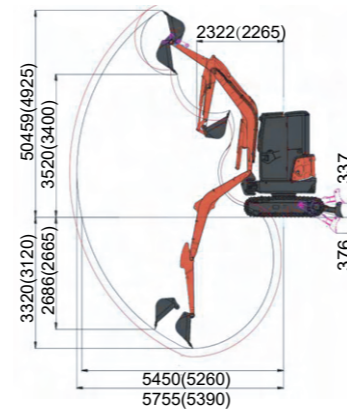
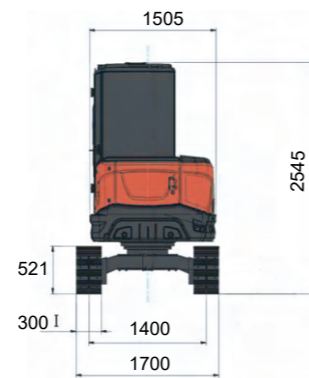
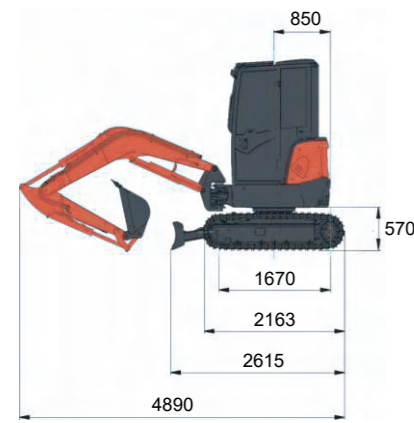

TECHNICAL PARAMETERS

Name		Data
Basic	Operating weight	3850 kg
	Standard bucket Capacity	0.11 m ³
	Standard bucket Width	520 mm
	Max.Travel speed	2.3/4.0 km/h
	Max.Swing speed	9.5 rpm
	Grade ability	30°
	Ground pressure	34 kPa
	Max.Traction force	27.4 KN
	Boom swing angle (L/R)	72°/44°
Engine	Engine brand	KUBOTA
	Engine model	D1703-4EB-SWD-1
	Rated power	18.2 kW/2200 rpm
	Displacement	1.647 L
	Fuel tank	40 L
Hydraulic	Max.Flow(total)	88 L/min
	Max.Working pressure	24.5 MPa
	Max.Pilot pressure	3.2 Mpa
	Max.Arm digging force	18(19.8) kN
	Max.Bucket digging force	31.8 kN
	Hrdraulic oil tank	41 L
Chassis	Track width	300 mm
	Track type	Rubber crawler
	Carrier rollers number	1(each side)
	Track rollers number	4(each side)
Electric	System vottage	12 V
	Battery capacity	12 V,45 Ah

STANDARD EQUIPMENT

Fops/Tops cabin
Suspension seat
Air conditioning
Hydraulic pilot control rod
Deflectable boom
Warning light
Breaker pipeline

OPTIONAL EQUIPMENT

Arm & arm safety valve
Dozer blade safety valve
Fops/Tops canopy
300mm width bucket
600mm width bucket
1200mm width bucket
300mm steel tracks

PRODUCT FEATURES

Kubota Strong Power Engine.Emission level reaches USA T4F and EU Stage V
The combination of zero-tail swing and boom deviation is designed for narrow and complicated working scenarios.
Wider space and view are provide by enlarged front windscreen and sunroof.
Touch panel monitor, electronic throttle rotating control and auto idling functions
The tail and right hoods can be opened completely to ensure easy and convenient maintenance.
Retractable chassis , good trafficability and more stable.

OPERATING WEIGHT:	3850kg
ENGINE POWER:	18.2kW
BUCKET CAPACITY:	0.11m ³
TRAVEL SPEED:	2.3/4.0km/h